

BSE with Individualized Emphasis 2020/21

Updated March 2020

This is not an official list of degree requirements. Adjustments may be required due to curriculum changes.

See back of academic plan for more information on requirements for elective courses.

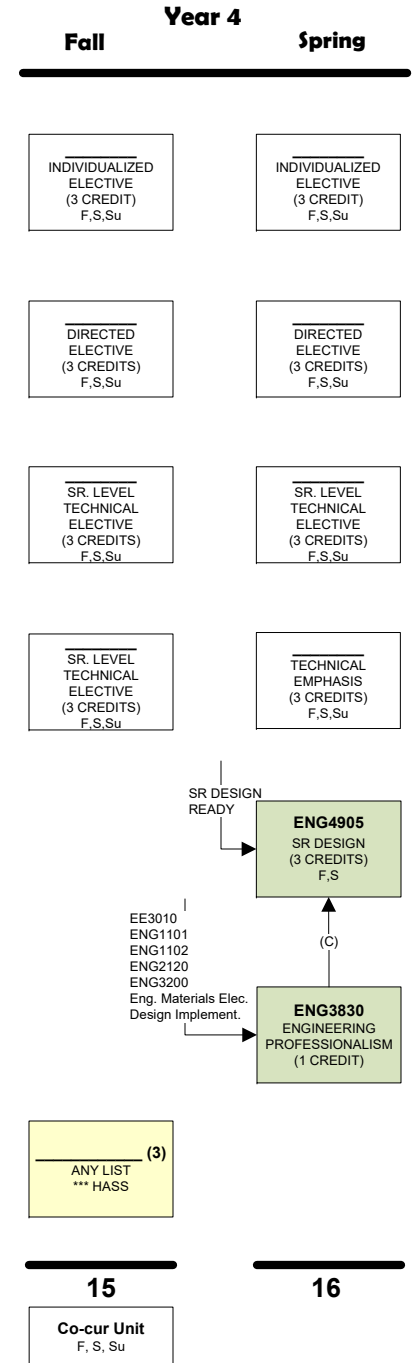
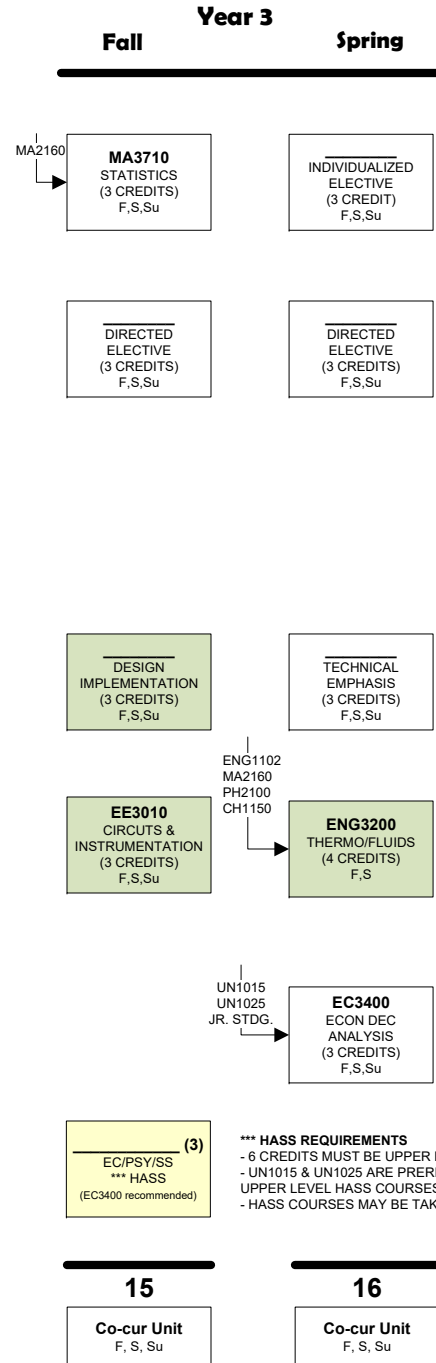
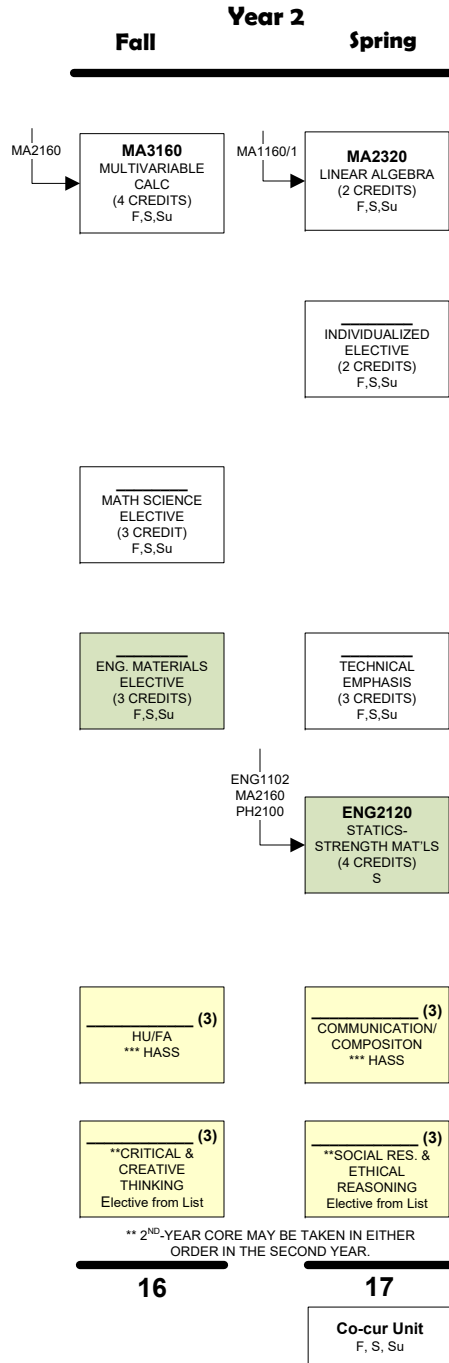
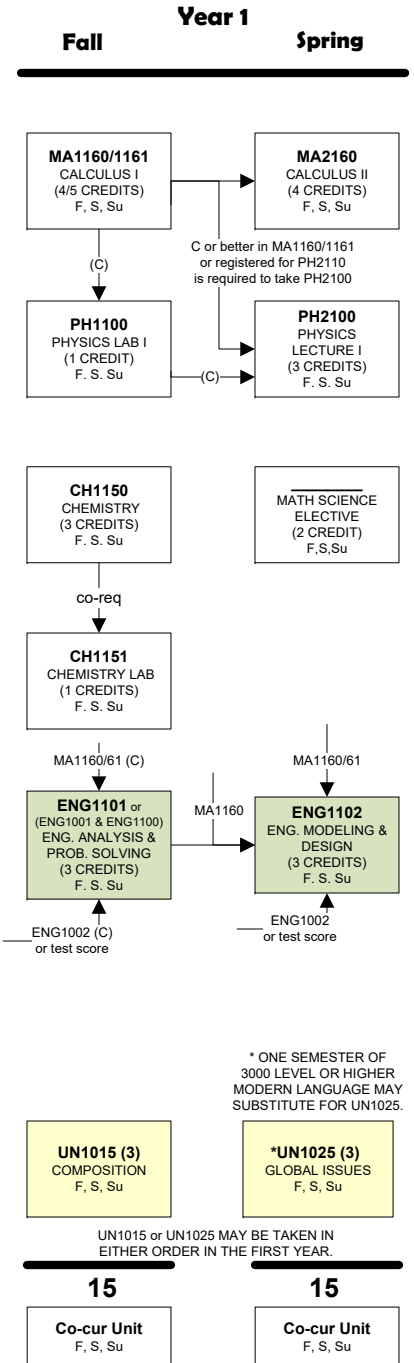
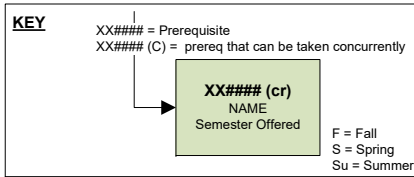

**BSE Individualized Emphasis 2020-21
(minimum of 125 credits)**

Academic questions: E-mail eadvise@mtu.edu

1 Senior Design **Prerequisite courses:**
ENG1101, ENG1102, ENG2120, ENG3200, ENG3830 (C), and EE3010.

2 General Education Requirements (24 credits + 3 PE units):

<p>I. Core Courses (12 credits)</p> <p>___ UN1015 Composition</p> <p>___ UN1025 Global Issues or 3000+ Modern Language _____</p> <p>___ Critical/Creative Think List _____</p> <p>___ Social Resp./Ethical Reason List _____</p> <p>II. HASS Courses Requirements (12 credits) (www.admin.mtu.edu/em/documents/HASS_Distribution_List.pdf)</p> <p>- 6 credits upper level (3000- 4999)</p> <p>- 3 credits from each listed below</p> <p>___ Communication/Composition _____</p> <p>___ Humanities/Fine Arts List (HU/FA)** _____</p> <p>___ Social & Behavioral Science List (EC/PSY/SS)** _____</p> <p>___ 3 credits from any list** _____</p> <p>* EC3400 is required by the degree, and may NOT be counted as a Social Resp./ Ethical Reason or HASS course.</p> <p>III. Co-curricular activities (3 units)</p> <p>In the co-curricular requirement, the three semester units will be physical education activities. These units are required for graduation, but are not included in the calculation of the GPA, nor in the overall degree-credit requirement. Note: most physical education activities will last for 7 ½ weeks or ½ semester. A student would need six of these ½-semester units to fulfill the 3-semester unit co-curricular requirement.</p> <p>PE _____ PE _____ PE _____</p> <p>PE _____ PE _____ PE _____</p>
--

3 Engineering Design Implementation (select 3 credits):

<p>___ CEE3332 ___ ENG4505 ___ GE3880 ___ MEEM3600</p>
--

4 Engineering Materials Elective (select 3 credits):

<p>___ CEE3101 ___ CS1121 ___ ENG2505 ___ GE2300 ___ MSE2100*</p>

5 Quality Control Elective (select 3 credits):

<p>___ MET4510 ___ MEEM4650 ___ OSM4650</p>

6 Math/Science Elective (select 4-5 credits)*:

<p>_____</p>

7 Technical Electives (18-19 credits)*:

<p>Select 18 to 19 engineering credits at the 3000+ level in a coherent plan of study that is approved by the Academic Advisor for the Bachelor of Science in Engineering program, Department Chair of Engineering Fundamentals and Academic Dean for the College of Engineering. 12 credits must be 4000+ level.</p> <p>_____</p> <p>_____</p>

8 Directed Electives (9 credits):

<p>Select 9 credits in a coherent plan of study such as partial fulfillment of a university approved minor, or a self-defined program with the advice of the BSE Academic Advisor.</p> <p>_____</p>

9 Individualized Electives (11 credits):

<p>Select 11 credits in a coherent plan of study that is approved by the Academic Advisor for the Bachelor of Science in Engineering program, Department Chair of Engineering Fundamentals, and Academic Dean of the College of Engineering.</p> <p>_____</p>

* If MSE2100 selected, then 4 credit Math/Science Elective and 19 credits Technical Electives needed.